

5. Transportation and installation

5.2.3.2 Installing LegaDrive Touch Basic handset



Fig. 20: LegaDrive Touch Basic handset

Install the handset under the desk top. To do this you will need the following tools:

- 1 x screwdriver
- 2 x screws

To install the LegaDrive Touch Basic under the desk top, proceed as follows:

1. Unpack handset.

	Note
	Dispose of the packaging material in an environmentally friendly manner (plastic film with plastic waste, cardboard with paper waste)!

2. Position handset at chosen position under desk top, making sure that the handset is in easy and convenient reach.
3. Attach the handset with 2 screws.

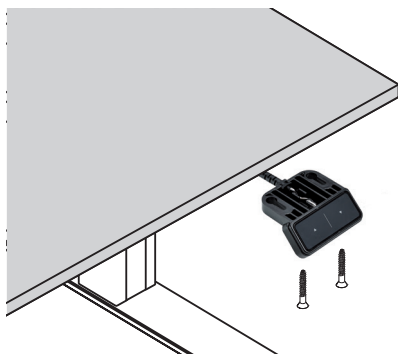



Fig. 21: Attaching LegaDrive Touch Basic handset to example desk

	Note
	The following screw types must be used for attaching the LegaDrive Touch Basic handset: - cylinder head screws - roundhead screws - panhead screws Maximum thread diameter: 4 mm Maximum head diameter: 7.3 mm

5.2.3.3 Installing LegaDrive Touch Basic Inlay handset



Fig. 22: LegaDrive Touch Basic Inlay handset

Install the handset at an appropriate position in the desk top.

To install the LegaDrive Touch Basic Inlay handset under the desk top, proceed as follows:

1. Unpack handset.

	Note
	Dispose of the packaging material in an environmentally friendly manner (plastic film with plastic waste, cardboard with paper waste)!

2. Drill / cut out an installation hole. The cut out is illustrated below.

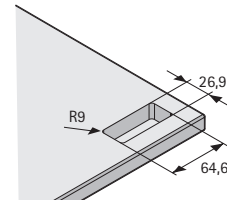

Fig. 23: Cut out for installing LegaDrive Touch Basic Inlay handset with rubber fins

3. Insert the handset from above into the previously drilled hole in the desk top. The handset is installed without additional screws, the rubber fins hold it in position.

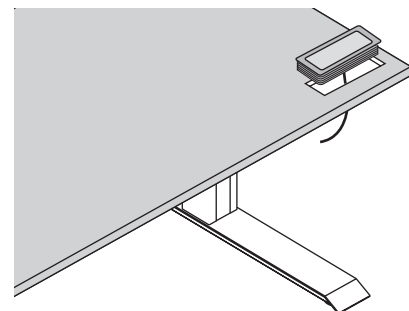

Fig. 24. Attaching LegaDrive Touch Basic Inlay handset to example desk